



FWD SEAGRAVE



Pumper

Why Buy A Seagrave

- Single Source manufacturer.
- Reputation proven in the toughest environments. (New York, Los Angeles, Washington D.C., Louisville, Albuquerque, Chicago, "Unified Fire Authority".)
- Full range of custom chassis, pumpers, & aerials.
- Cabs built with "Structural Safety Cage Design".
- **Stainless Steel** Construction for extreme durability and corrosion resistance
- Skilled & dedicated employees with an average of 18 years of experience. (Many with Fire fighting & Rescue experience)
- Full customer support after the sale.
- Proven longevity by being the only apparatus manufacturer that has been in continuous operation since 1881.
- AutoCAD, **3D modeling (Solid Works), FEA (Finite Element Analysis)**
- Low maintenance designs that provide ease of access for mechanics
- Low cost of ownership
- Best Lifetime Value in the industry
- **A Seagrave fire truck is an Investment in unparalleled Safety, Longevity and Reliability**



Facilities



- 540,000 total square foot facility on 58 acres
 - Fabrication & Paint - 243k Sq Ft (1914)
 - Assembly & Testing - 137k Sq Ft (2006)
 - Tilt Table and Pump house (2012)



Testing Grounds

- On site vehicular testing track
 - Paved oval test track with a skid pad testing area
 - 60' diameter circle with concrete pavement for steering systems check
 - 20 percent grade ramp for hill-holding and grade-ability testing
 - Full chassis alignment facility
 - Indoor pump test facility with tilt table



Front Bumpers

- Std Bumper
- Painted Bumper
- Polished Angled Bumper
- Linex'd Angled Bumper

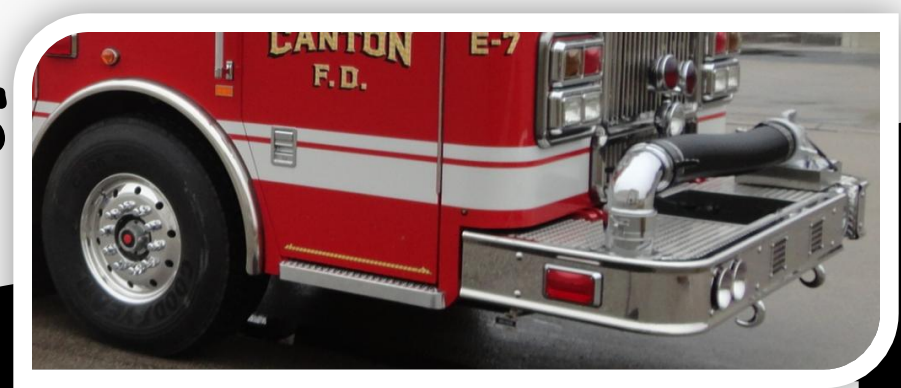

Front Suctions



Rear Tow Eye Option

Cut Plate



Loop



Steel or Alum Wheels



or



Grease Seals or Oil Seals



Air Lines

Color Coded
Down Driver's Frame Only

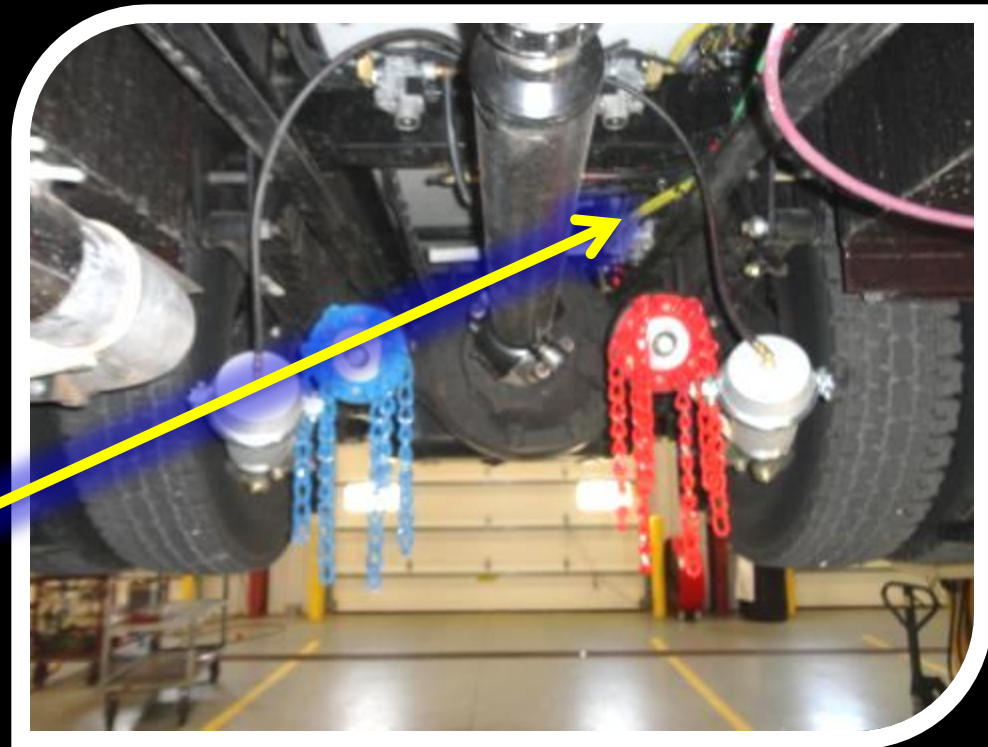

DPF / SCR



Optional Guard

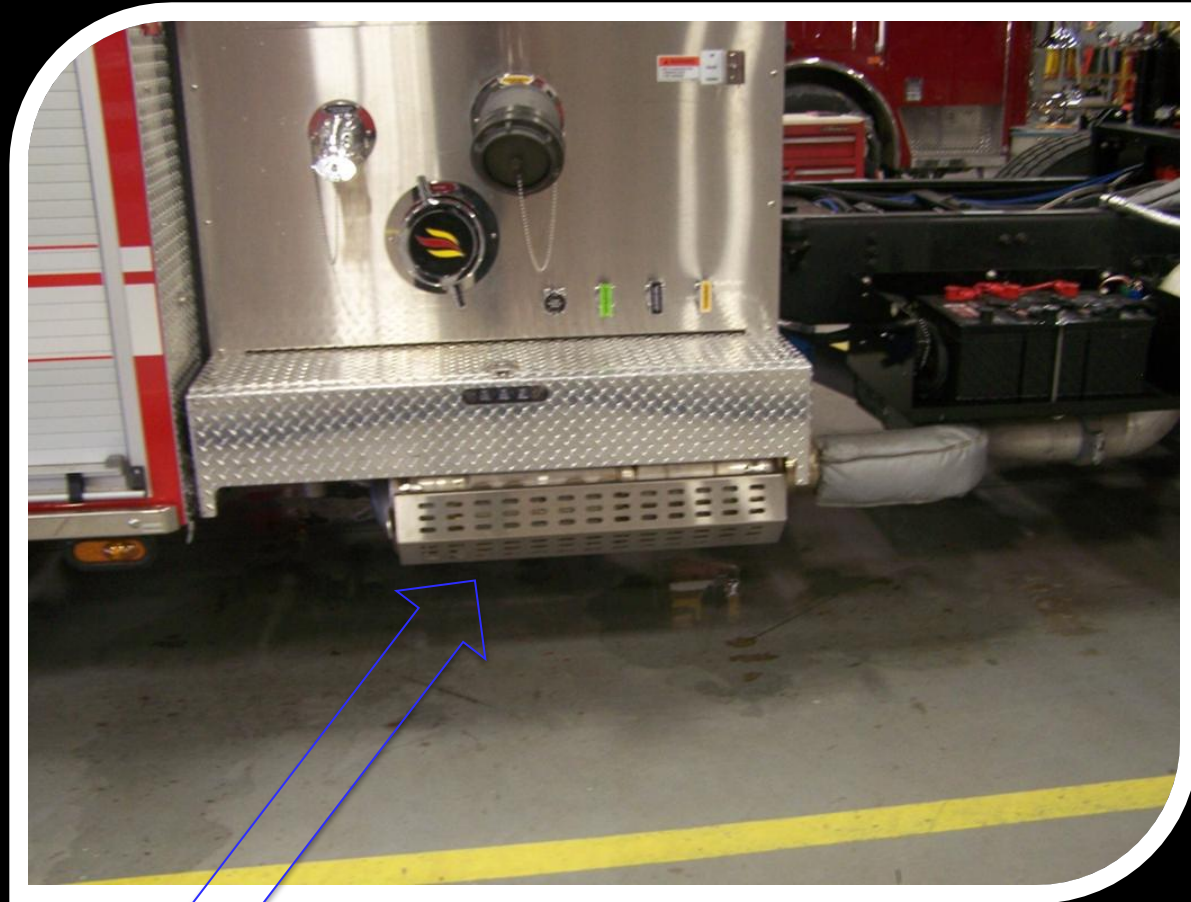

DEF Tank



Air intake & Filter

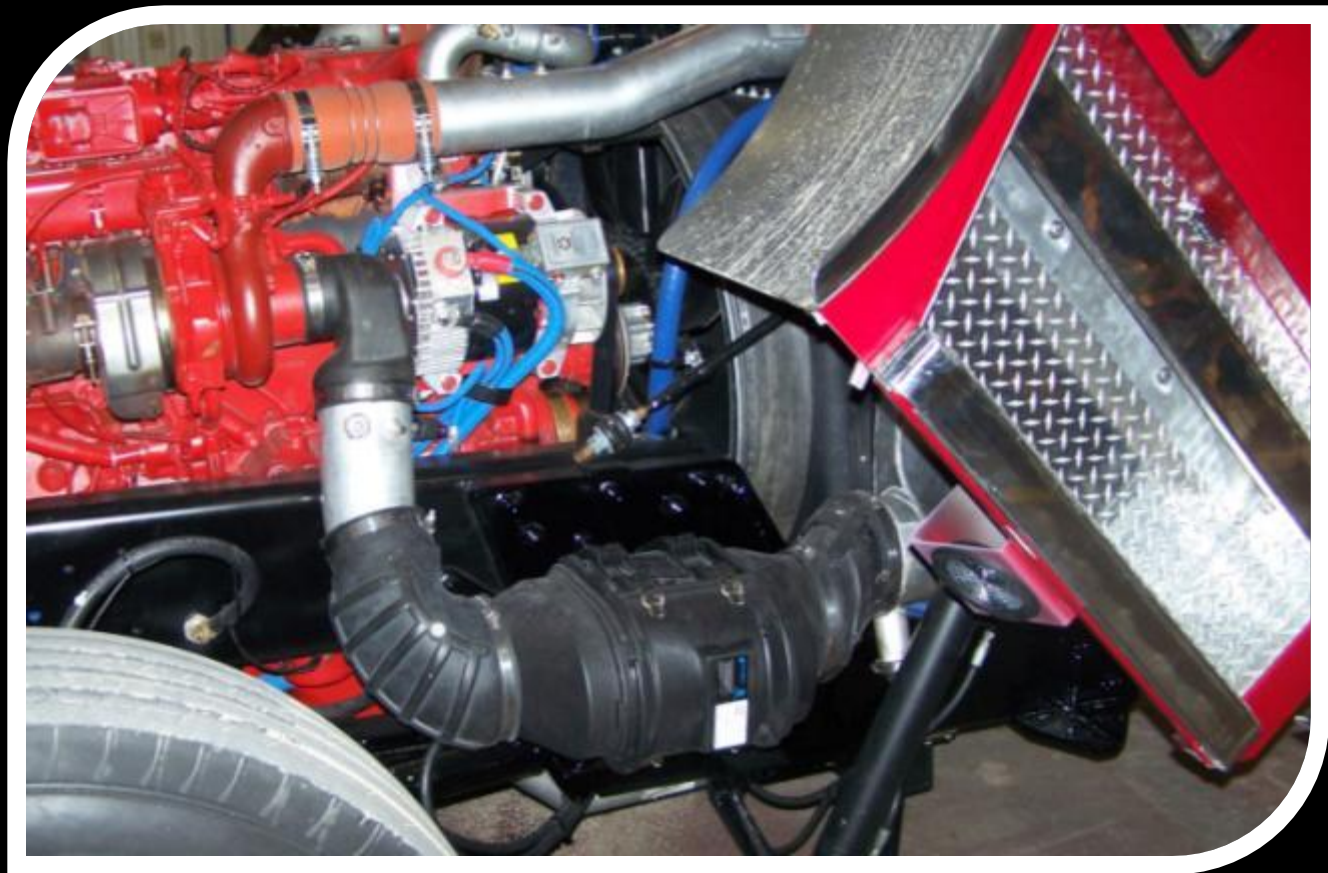

Air Intake



Radiator Overflow



Fuel Fill



S/S Marauder cab



Cab Structure

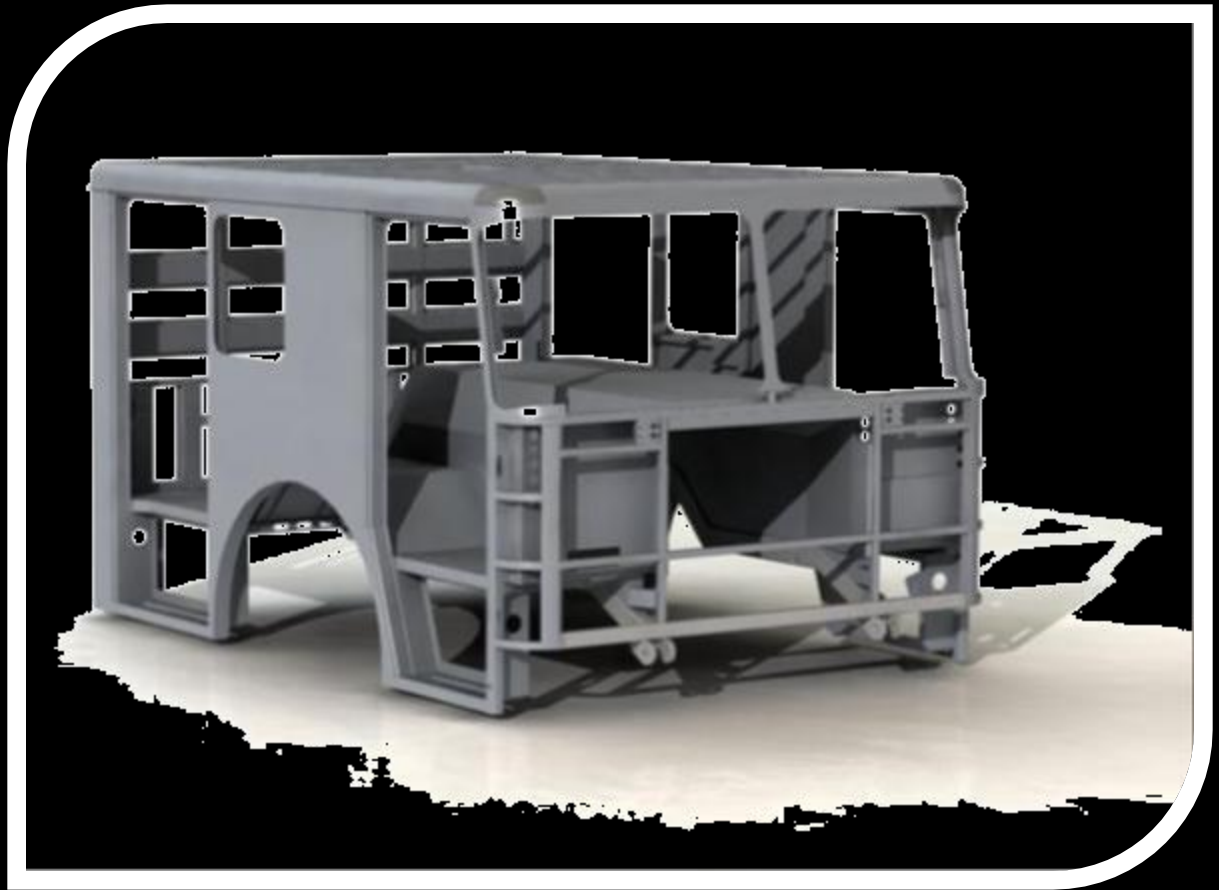

Seagrave Safety Cage

Massive
Front End

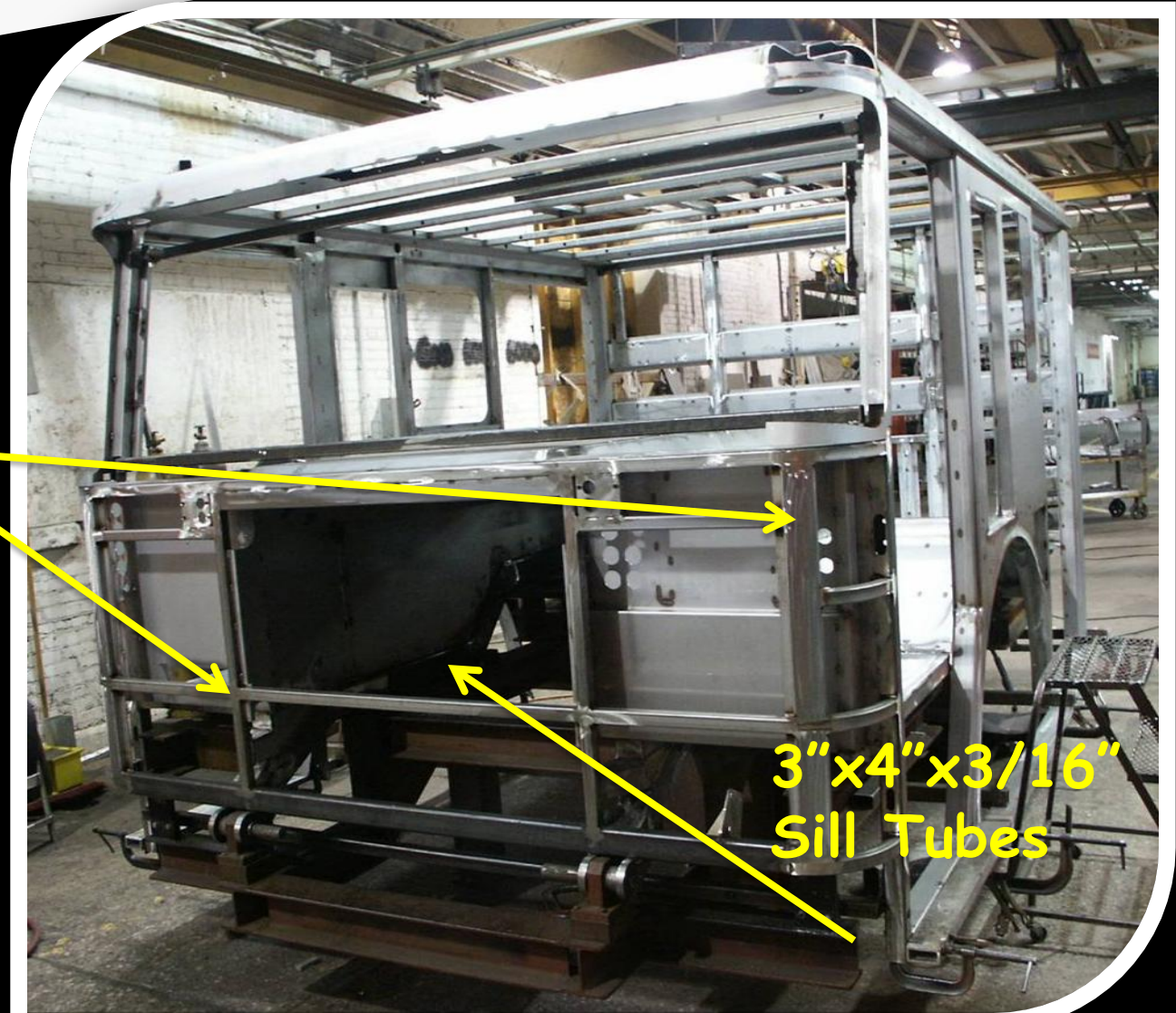

Safety Cage Occupant Safety

Compare !

Seagrave

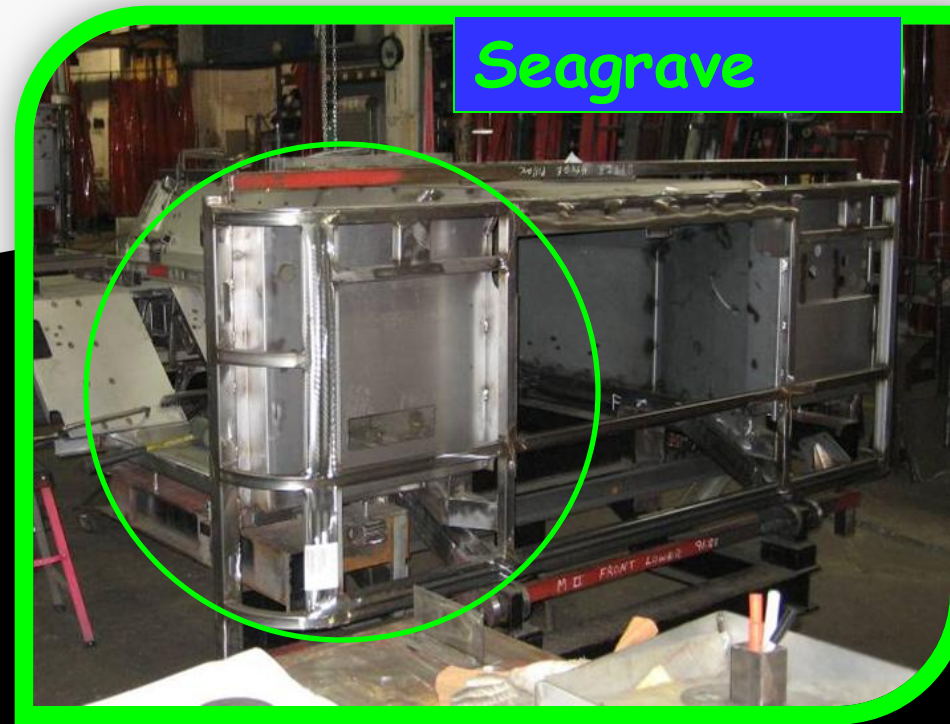

Competitor



Competitor



Seagrave Safety Cage

1-1/4" x 3/16"
Tubing.

Welded Nuts
for long life
support

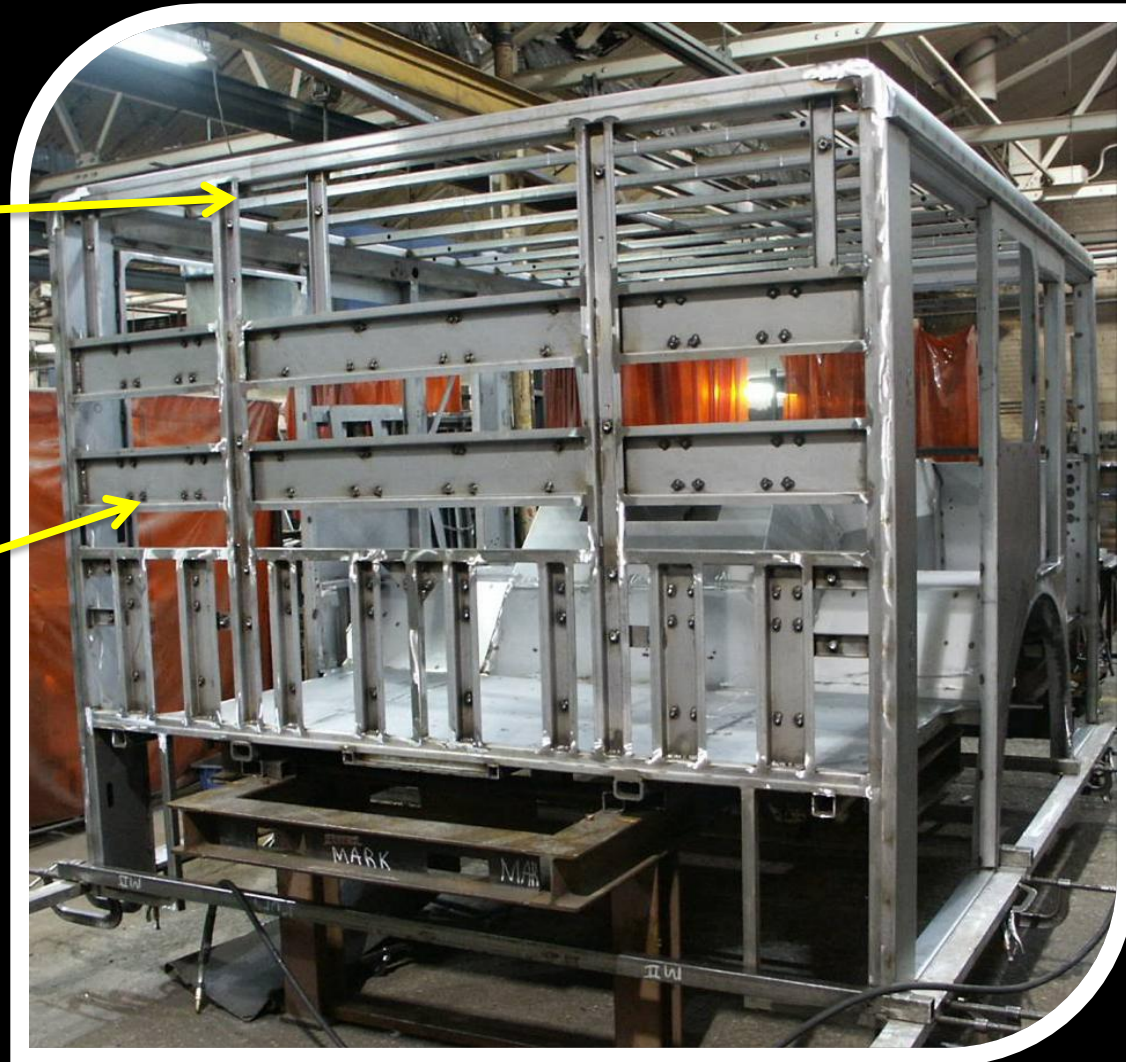

Cab Doors

- Barrier Doors (std)



- Long Doors (opt)



Inner Door Panels

- Upper

- Lower



Linexed S/S Panel Option

Stop Sign Optional



Back Wall Options

strips

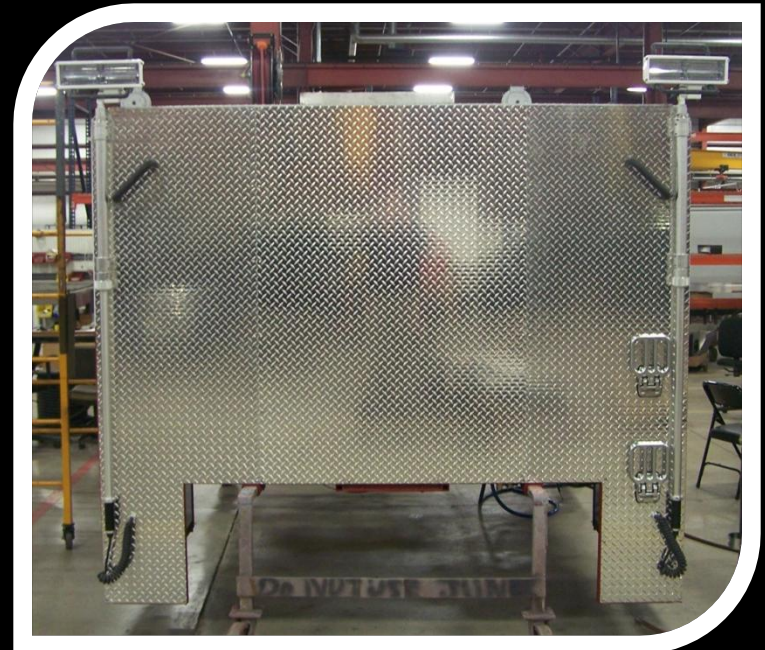
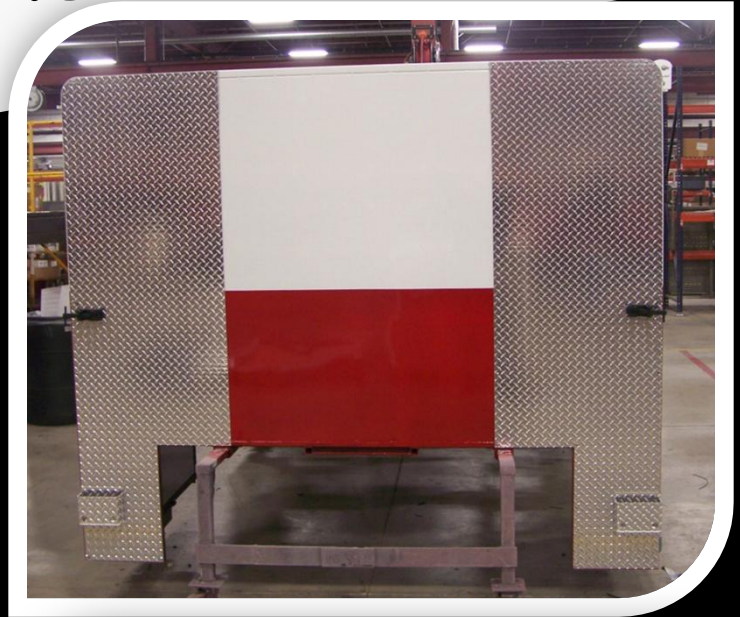

Full



Cab Roof



Raised Roof 8" or 16"



Intermediate step



Cab Access Doors

• 25"

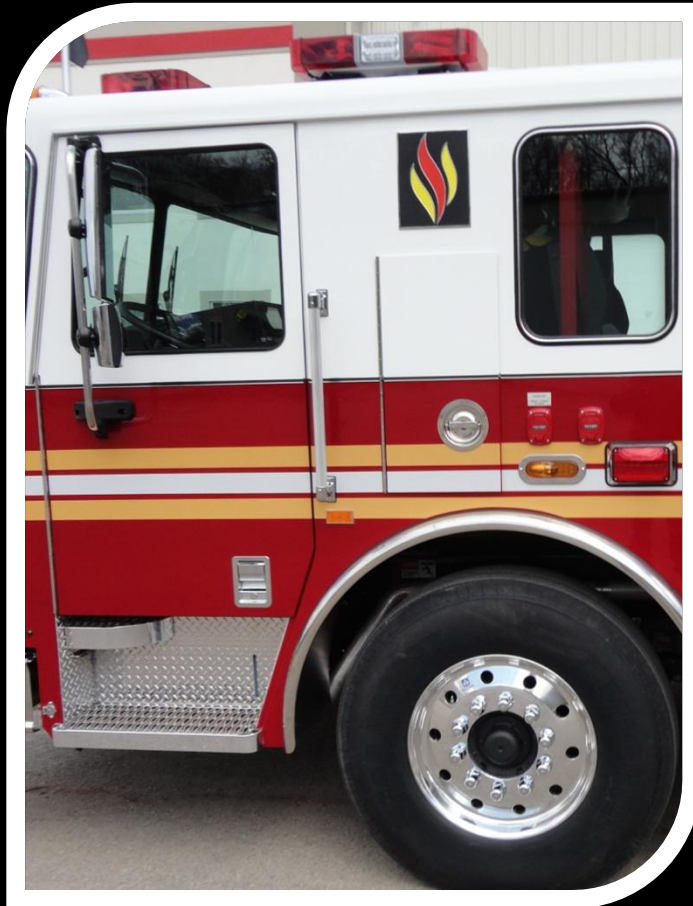

37"

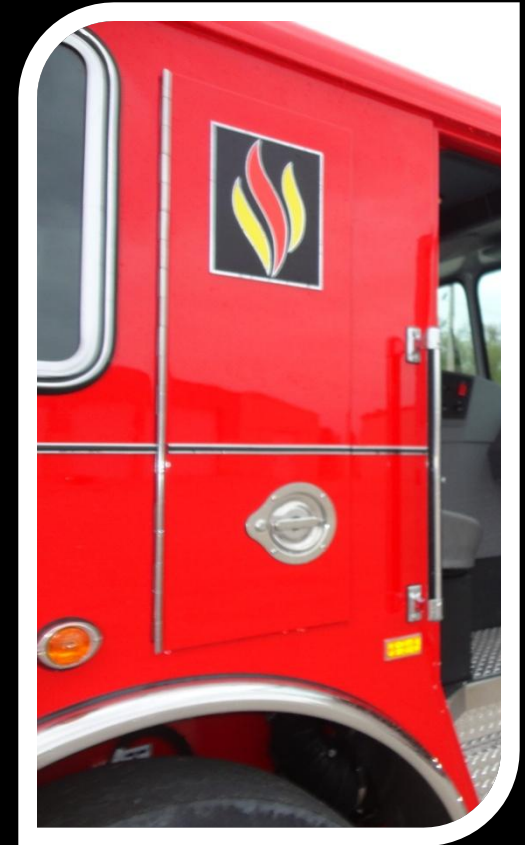

Cab Access Doors

- Optional Driver's side compartment



Fenderettes



Polished S/S



Optional Rubber



Mudflaps



Mirrors



Washer Bottle Fill



Crew Handrail



Optional Front Handrails



Driver's Area



Master

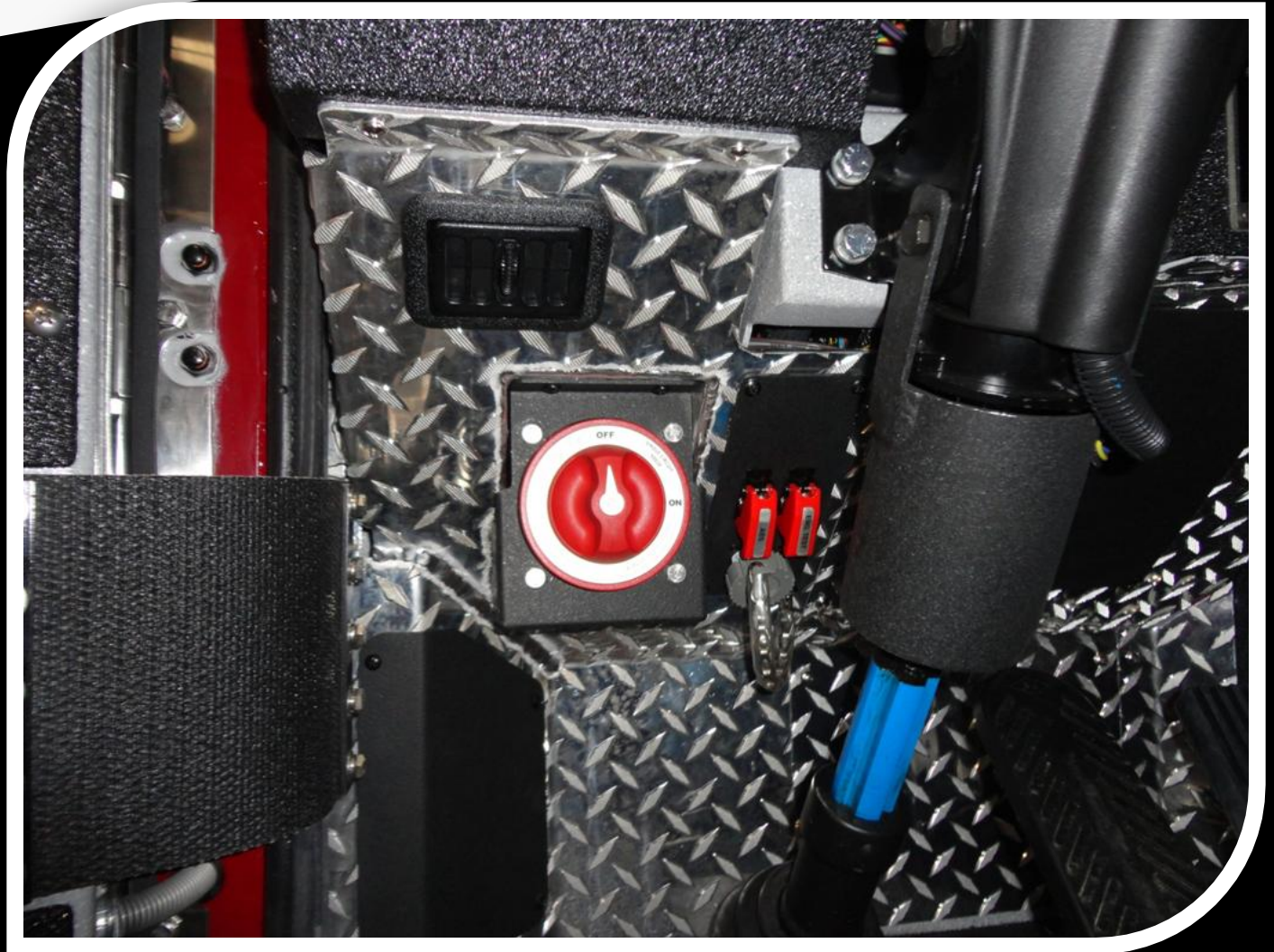

Sun Visors

Lexan



Vinyl



Vehicle Dimension & Weight Placard

Located over driver's door



Zone #16



Officer's Area



Lower Cab Dash Area

- Angled switch panel and transmission pad by driver for greater ergonomics
- Added area for laptop computer install by officer

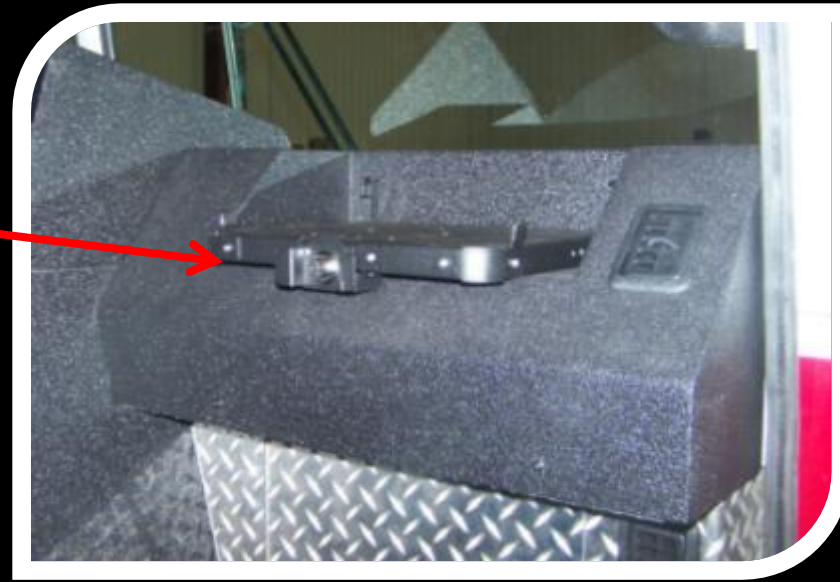
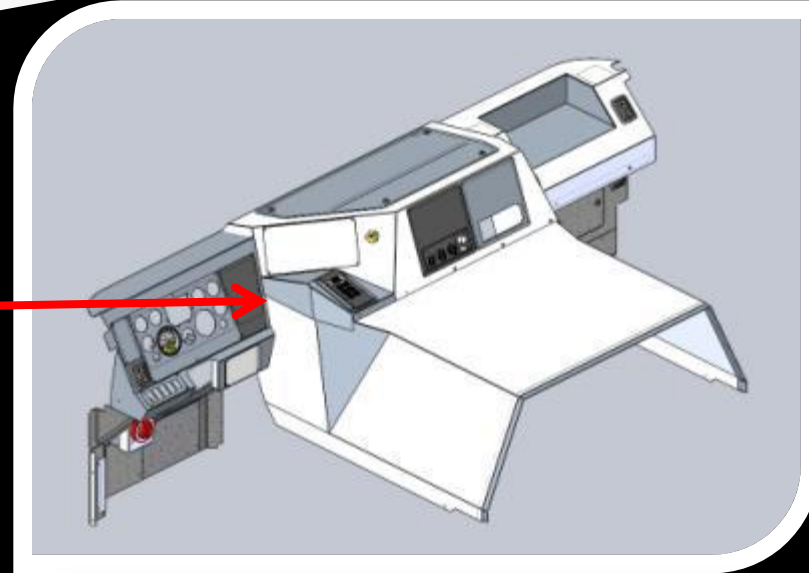

Optional Elbow Pads



Upper Panels

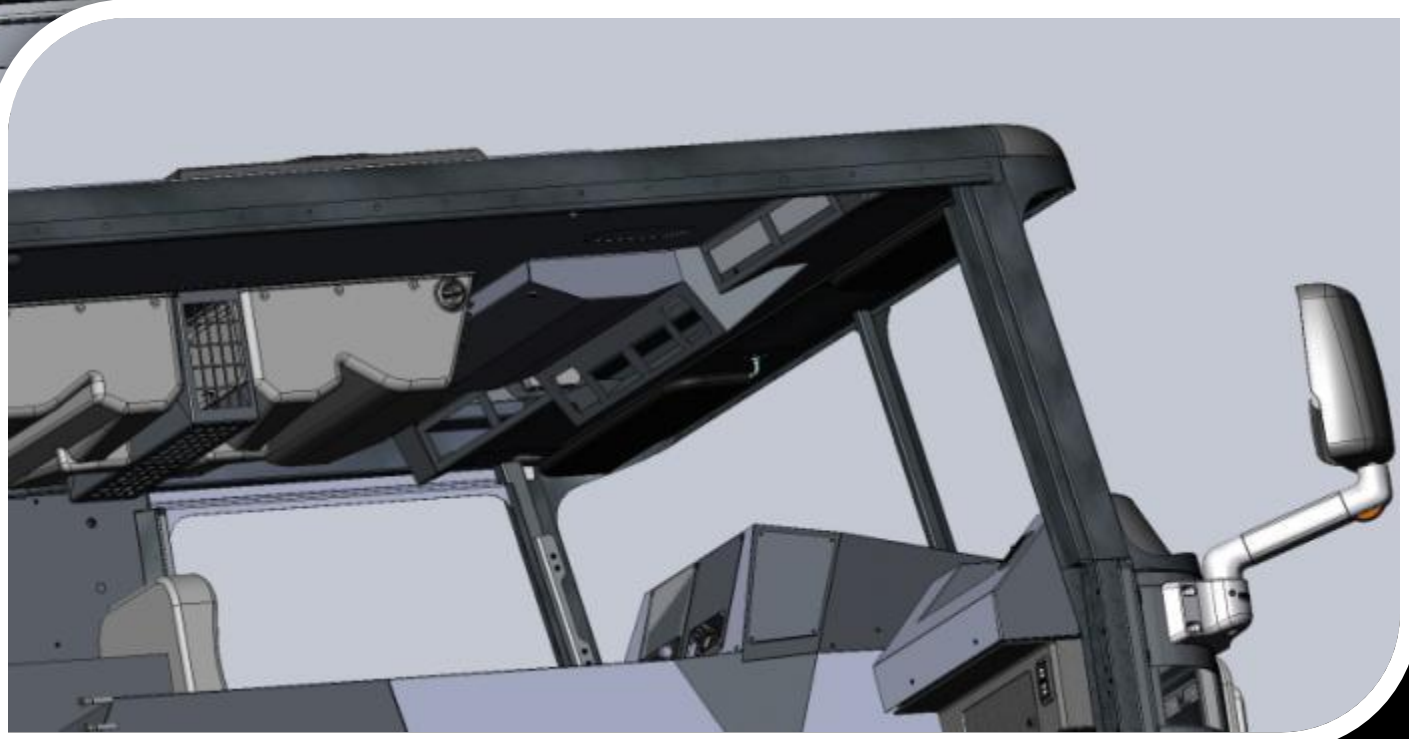

Cab Seating

131 cab

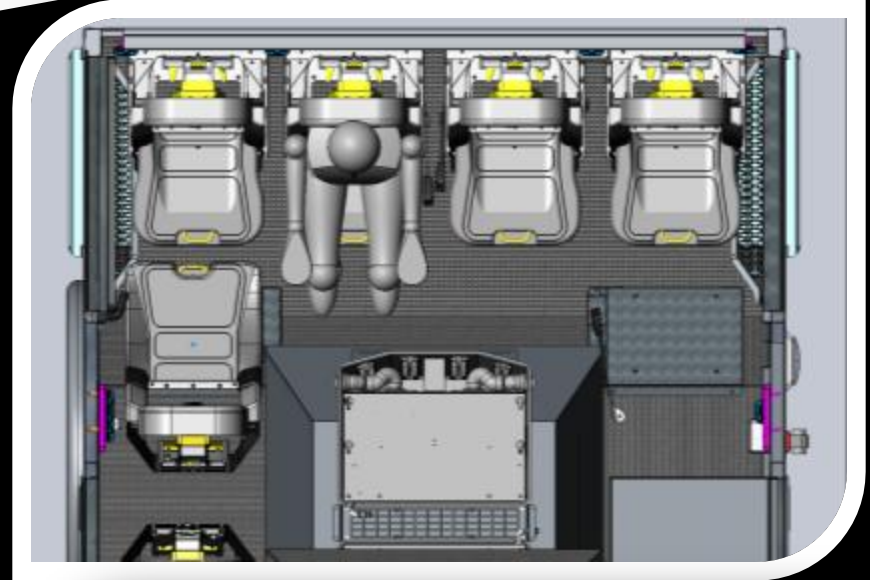

141 cab

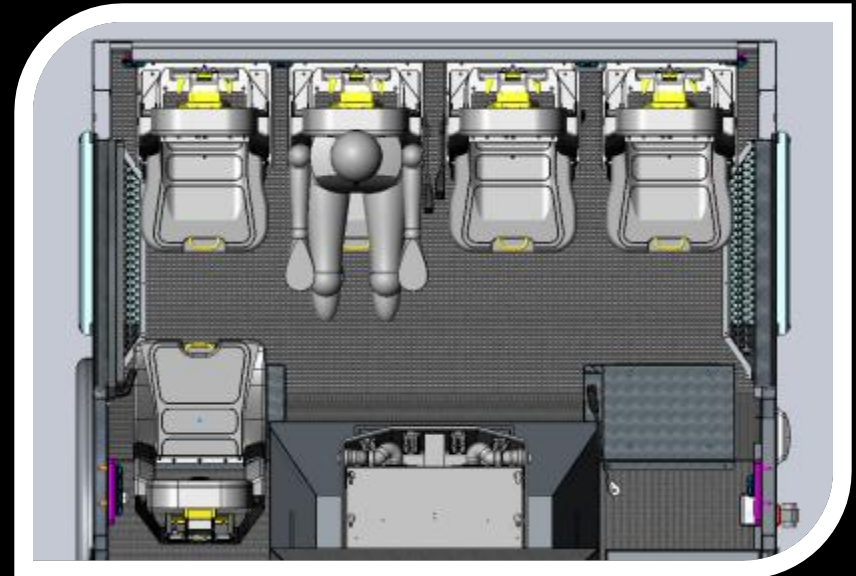

Under Seat Compartment



Engine Tunnel Substructure



A/C Heat Controls



Defroster



Rear Evaporator



Crew Heaters

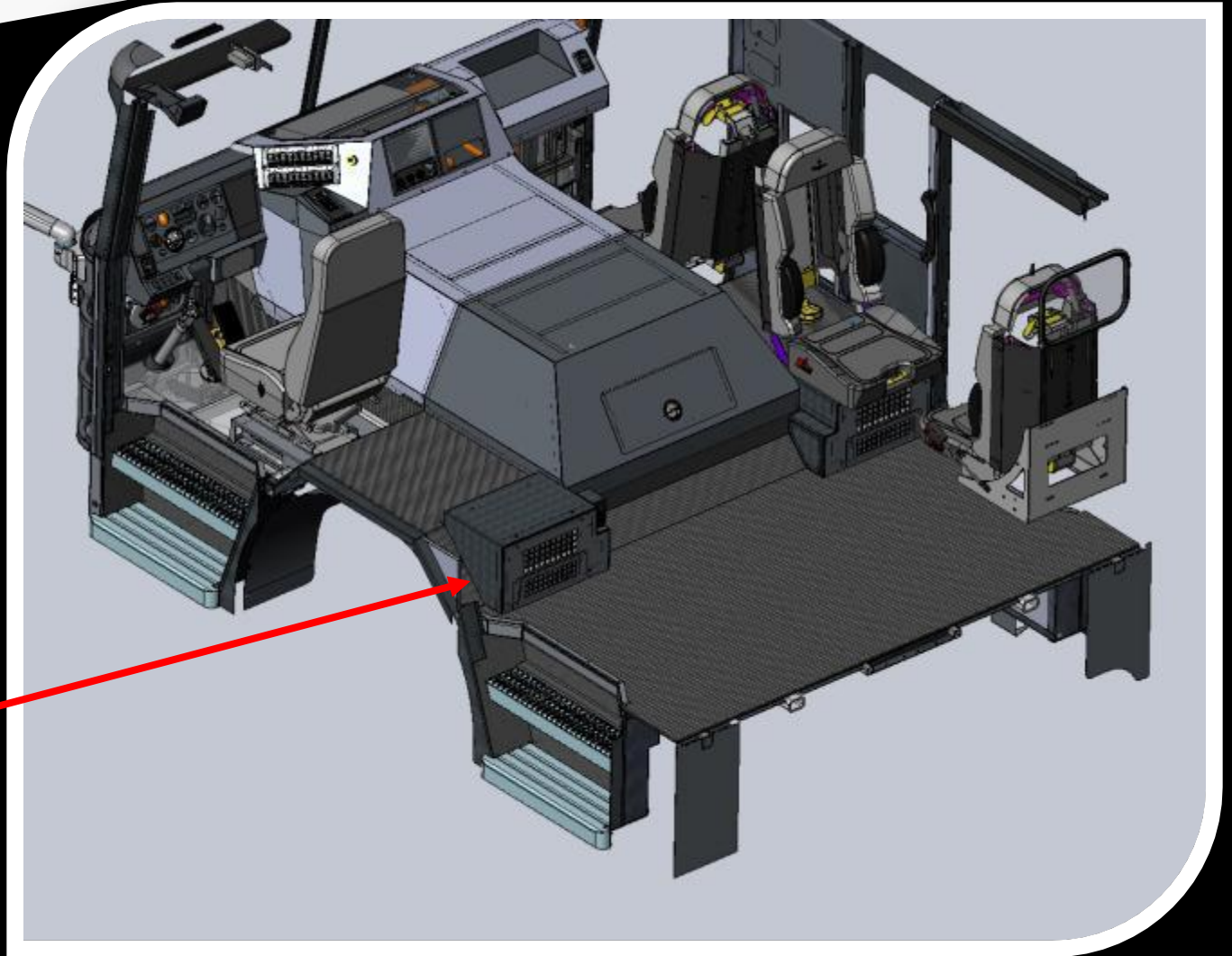

HVAC Shutoff Valves



Map Box / Cup Holders



Driver's Dash



Dash Layout

CAB CONTROL AND INDICATOR LOCATION WORKSHEET

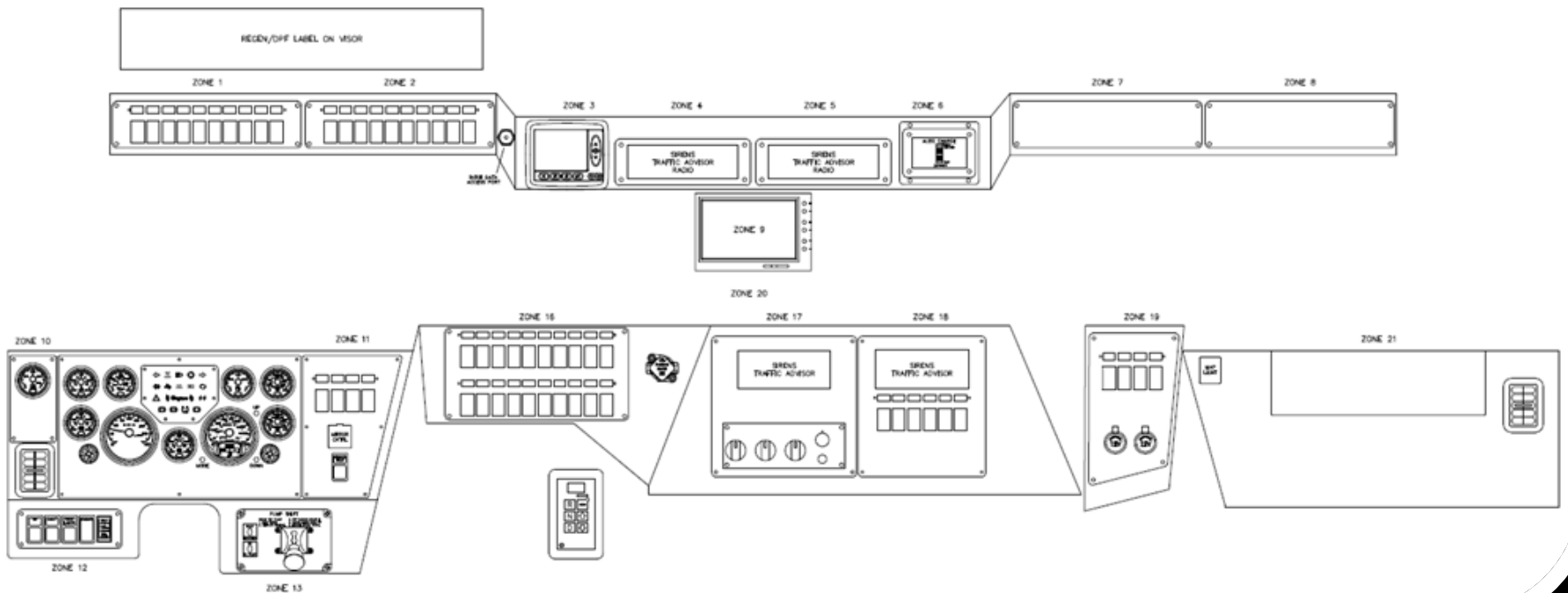

Info II Center--Hardwire



Data Recorder Jack



Intelex Plus

- Bussmann Vec Multiplex module gives the familiarity of a hardwired system making maintenance easy—also the display screen in the cab will show personnel exactly which relay has to be changed



Battery Charger

On Wall Behind Driver's Seat



Cab Knockout Panels



LED FVMSS lights

-

Brow

versus

Pedestal



Side Marker on Cowl

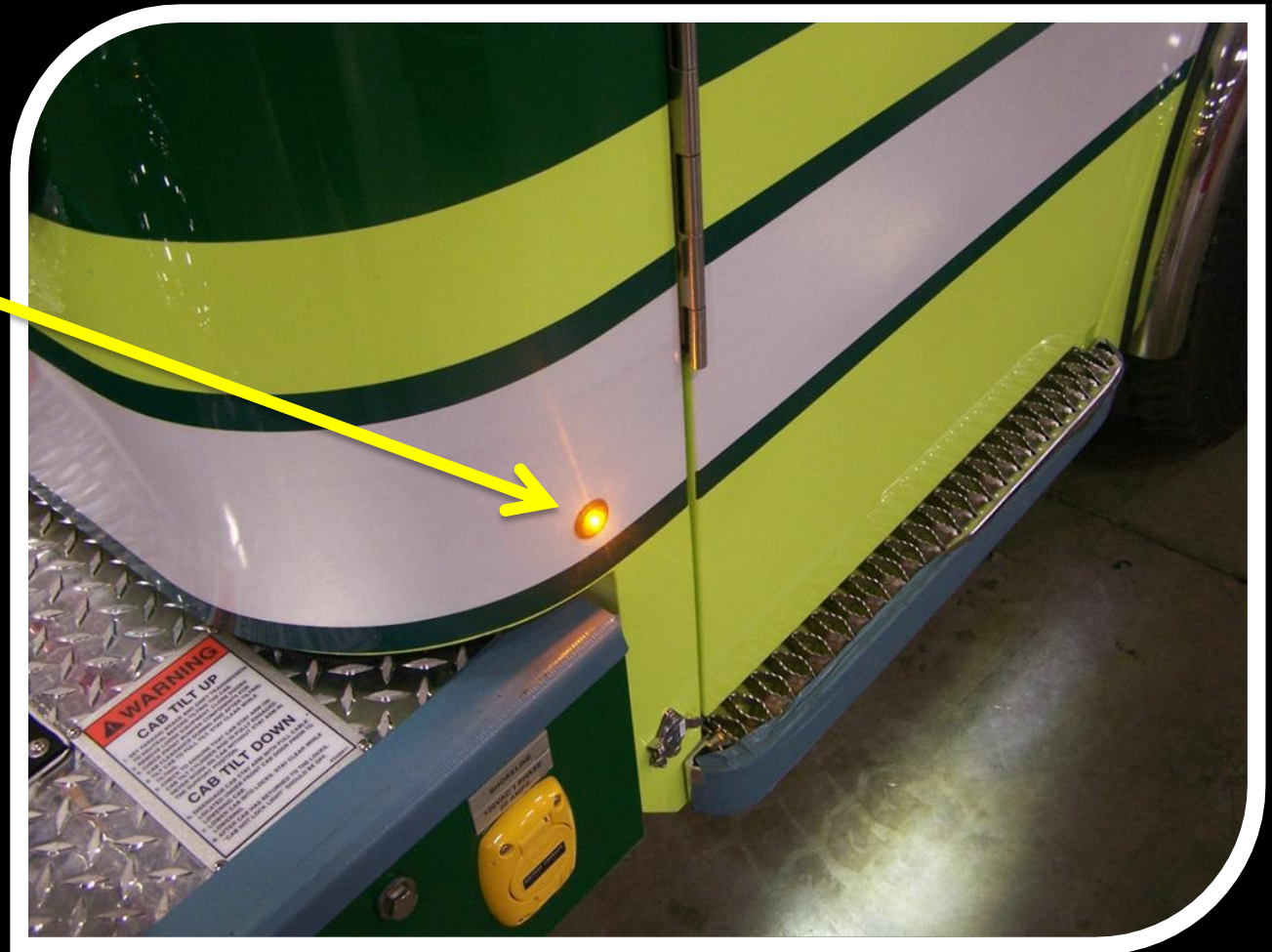

Reflectors

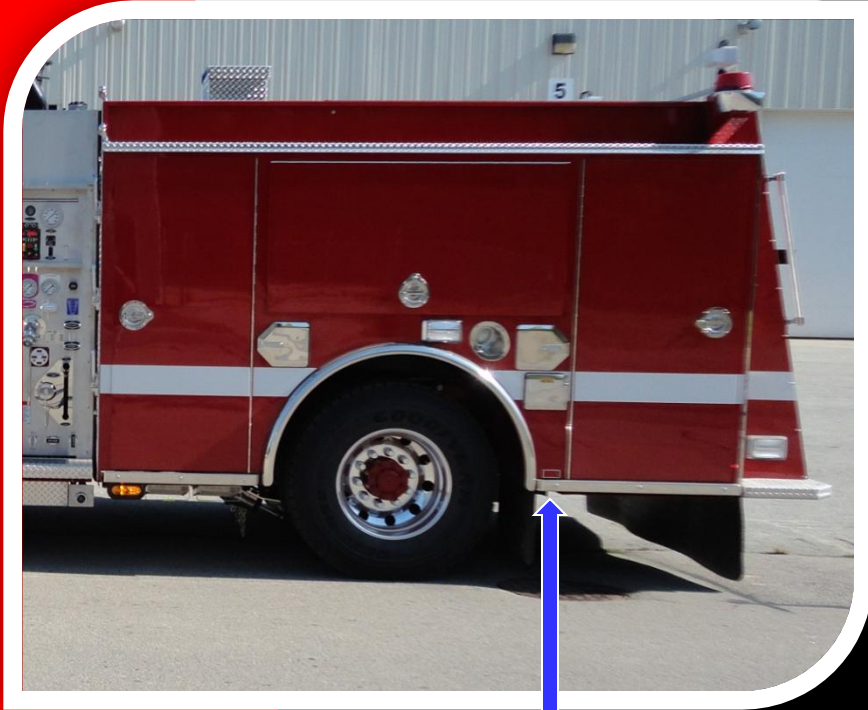

Directional light options



Map Desk - Map Lights

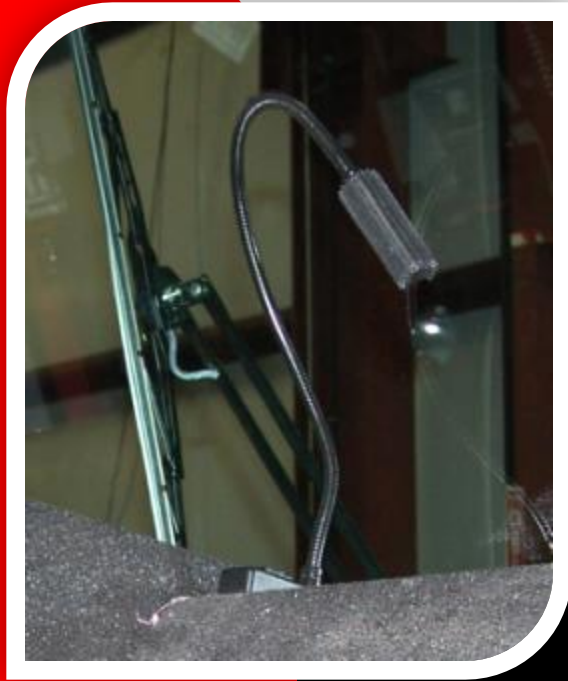

Techniq Backup Light



Pump Panels

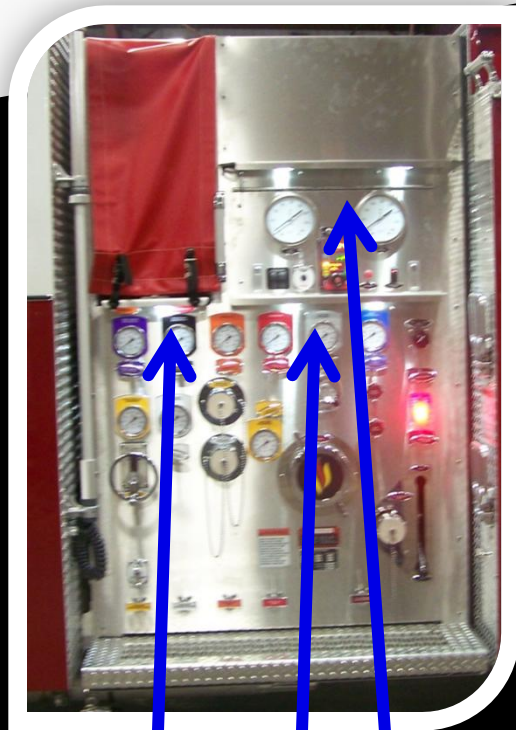

Lights



seagrave

- Brushed

- Linex'd

Exhaust Shield Step



Pump Plumbing Access Door



Top Mount



Water Pumps

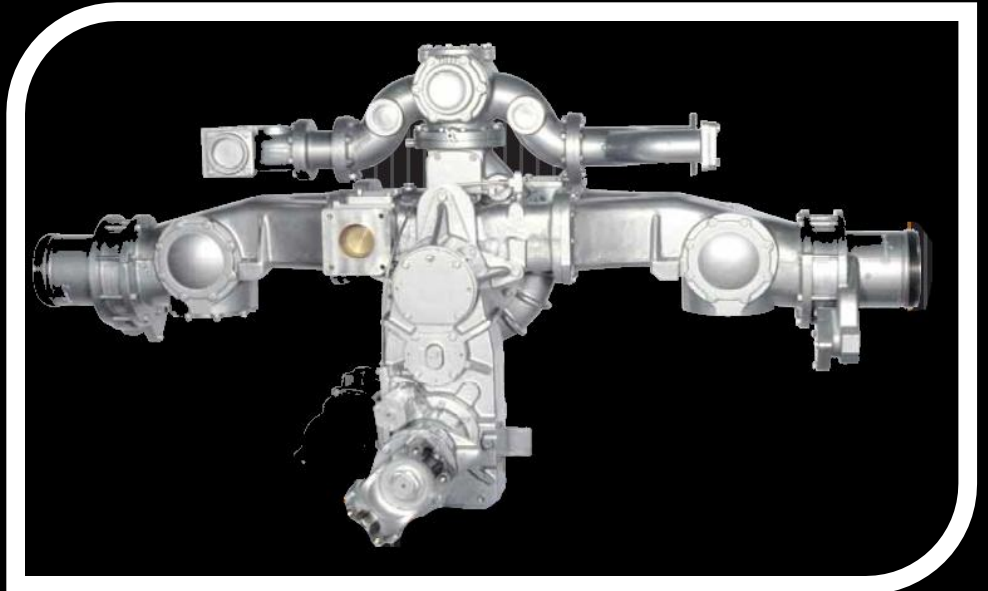

Labeling

Labels allow for dual designators



Manifolded Pre-Engineered Plumbing

Belled End Fittings—no butt welding

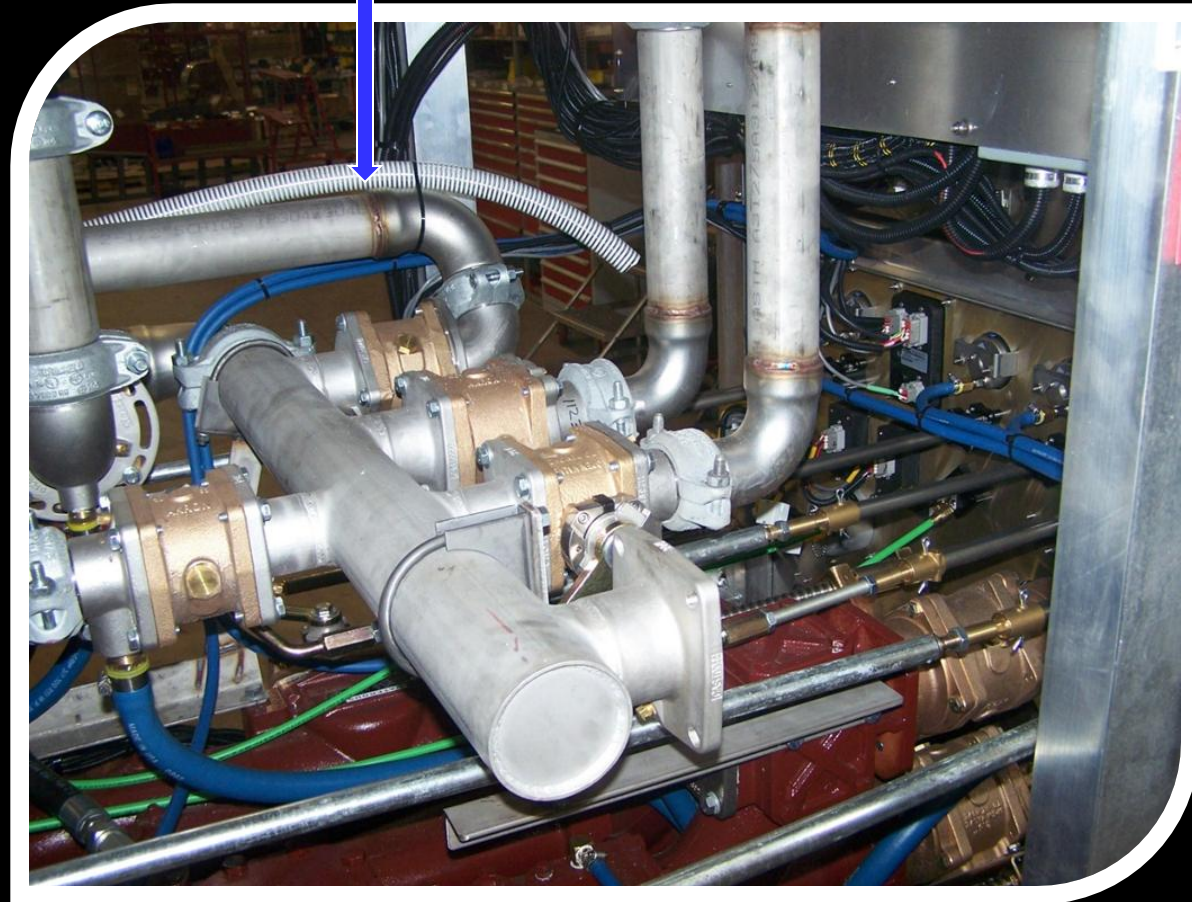

Door Liners

ATP—std.



Brushed S/s
--optional

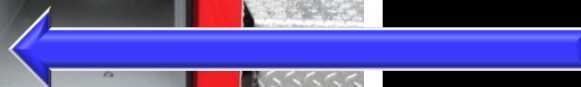

Compartment Details

Shield

Access
Panel



Optional Rear Partitions

Vents



Side Receivers for Winch



Pegboard / Slats

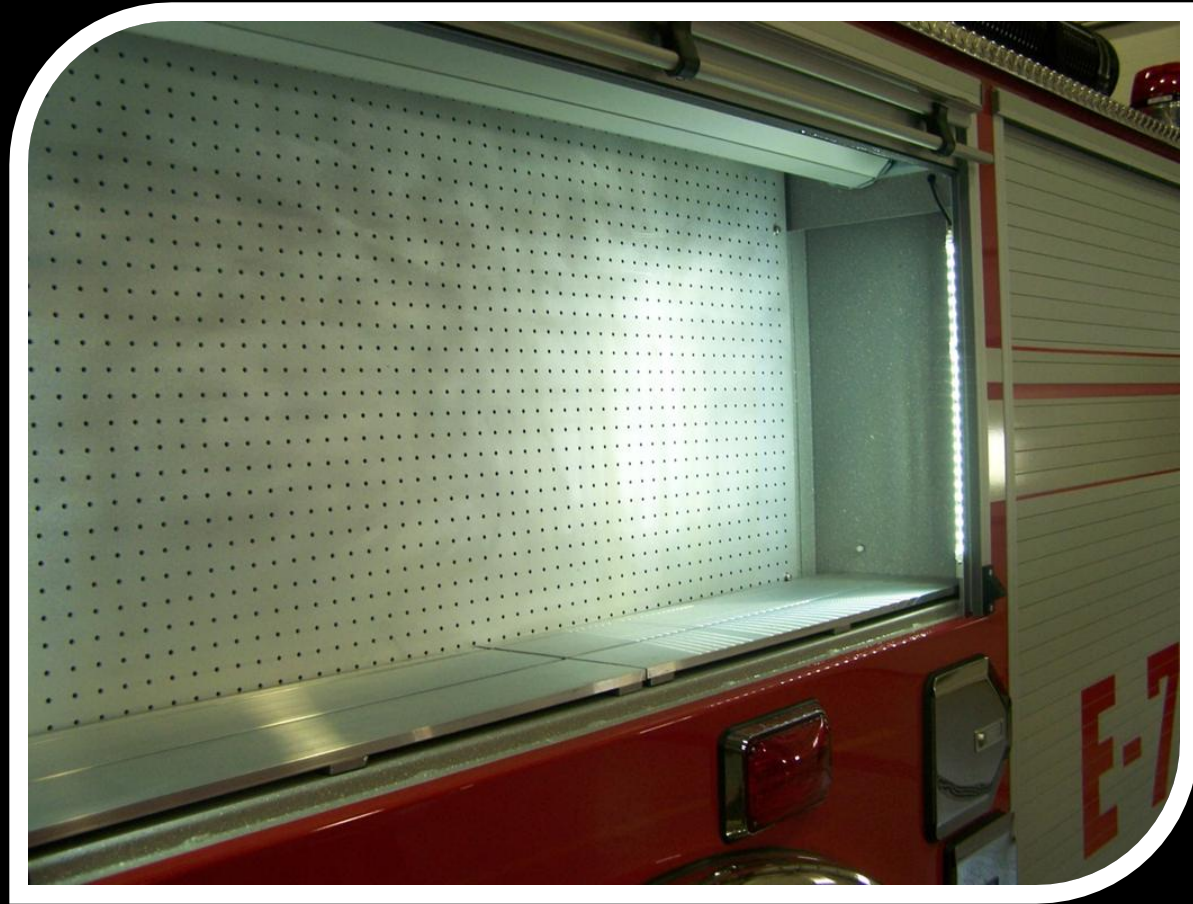

Hosebed

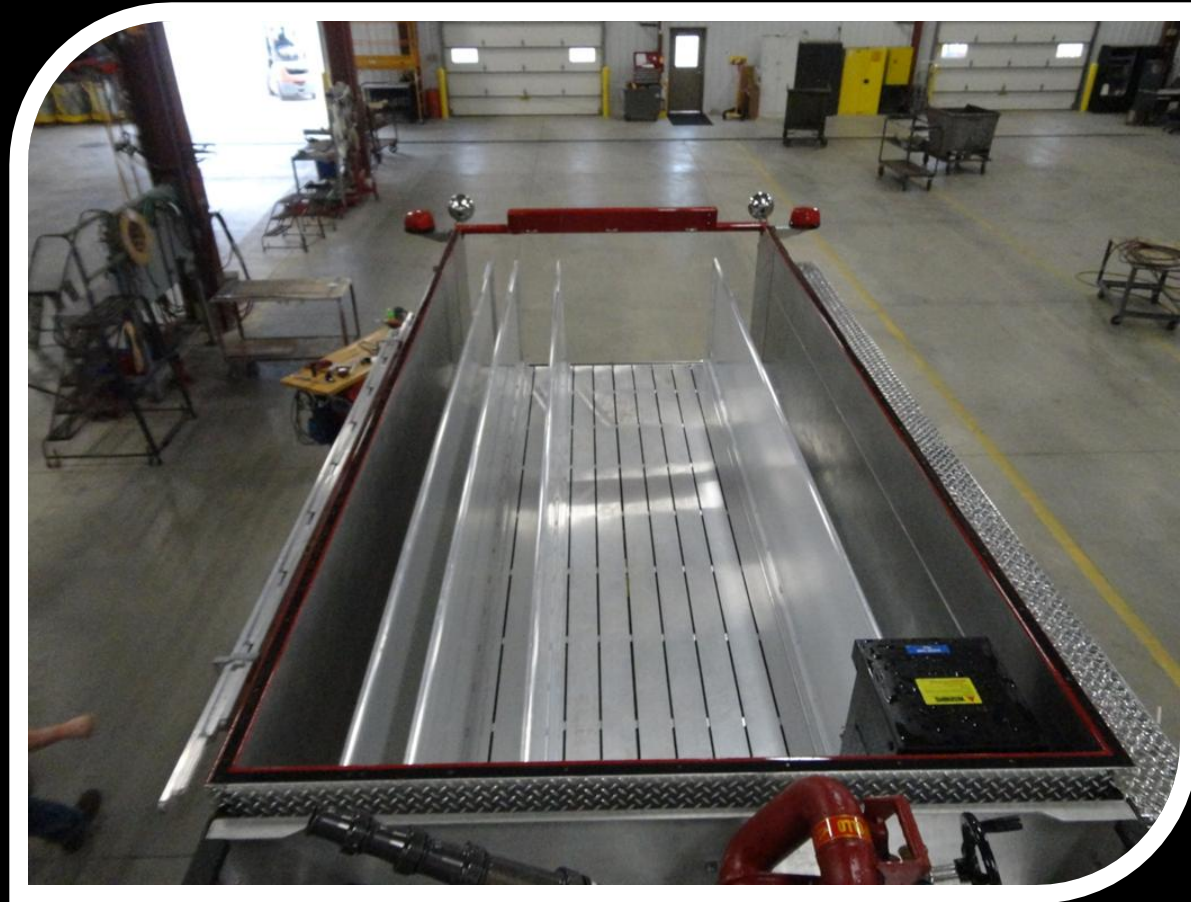

Hosebed Cover w/A Frame Support



Hosebed partitions



Bottle Compartments

Painted



Mirror



Brushed



Zico Quic Ladder



Rub Rails

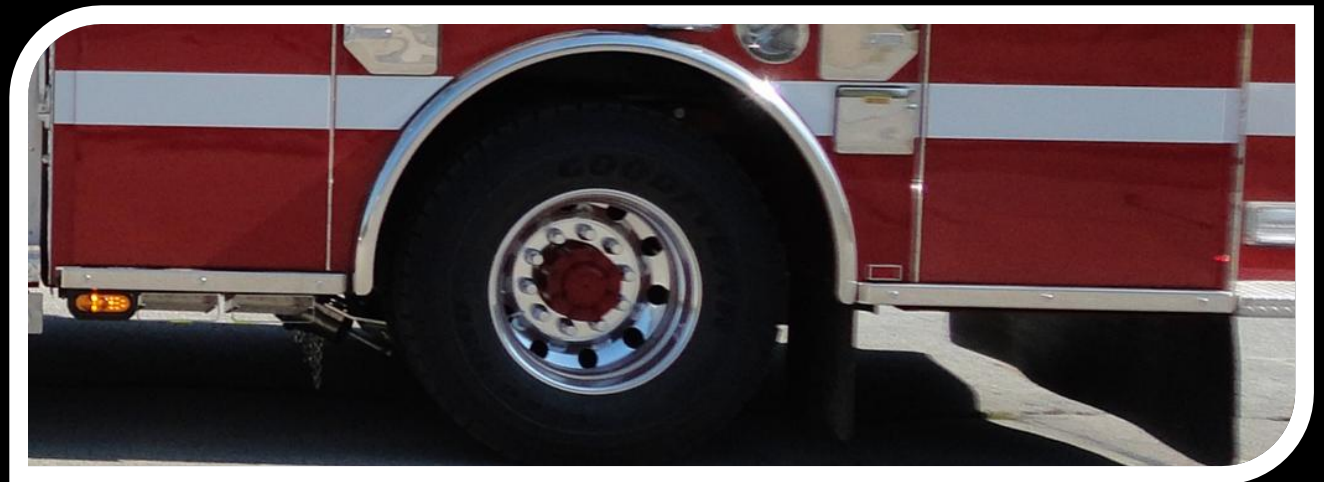

Rear Chevron



Front Chevron (optional)



5G Radius

Seagrave

